

FRONT ELEVATION

GABLE

MATERIALS AND SPECIFICATIONS ABOVE ARE APPLICABLE TO ALL SIDES OF THE ACCESSORY DWELLING UNIT.

FRONT ELEVATION

GABLE W/PORCH OPTION

MATERIALS AND SPECIFICATIONS ABOVE ARE APPLICABLE TO ALL SIDES OF THE ACCESSORY DWELLING UNIT.

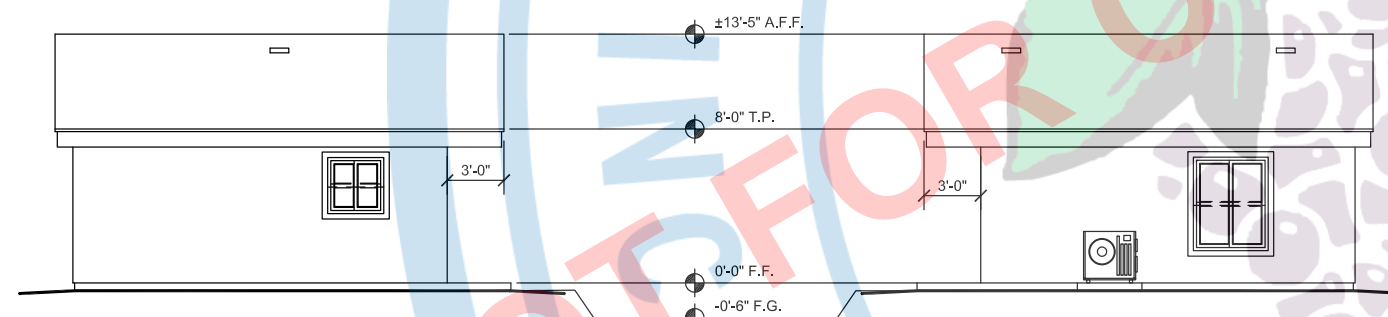

LEFT ELEVATION

GABLE

RIGHT ELEVATION

GABLE

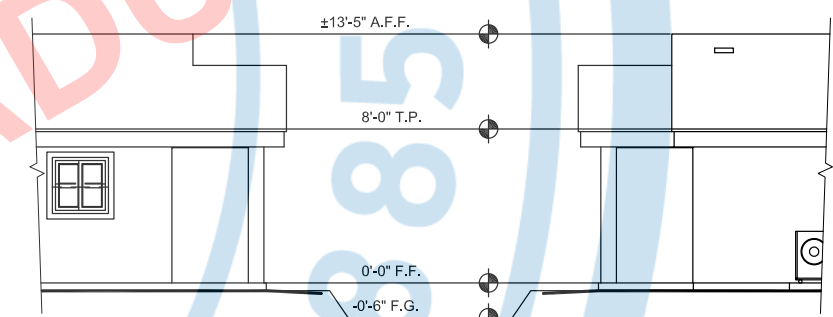

LEFT & RIGHT ELEVATION

GABLE W/PORCH OPTION

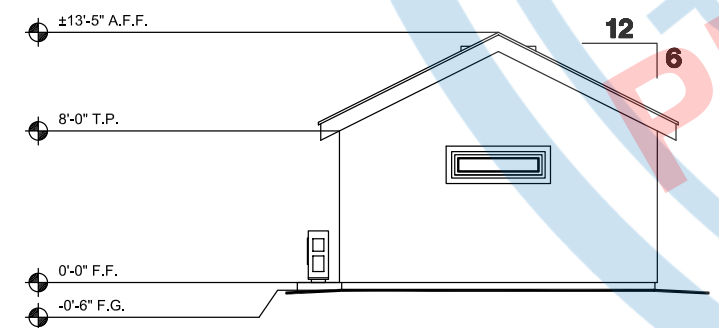

REAR ELEVATION

GABLE



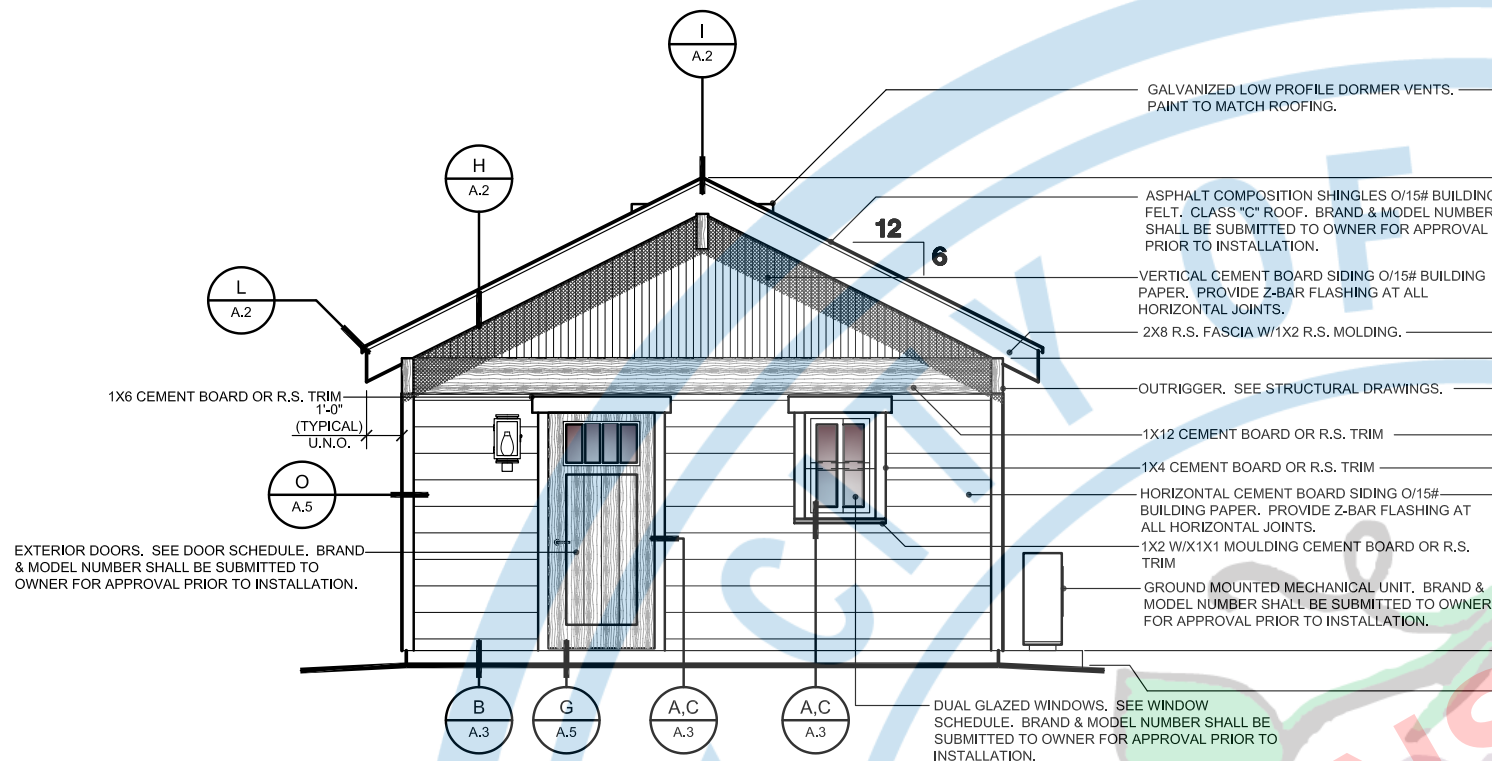

FRONT ELEVATION
CRAFTSMAN
MATERIALS AND SPECIFICATIONS ABOVE ARE APPLICABLE TO ALL SIDES OF THE ACCESSORY DWELLING UNIT.

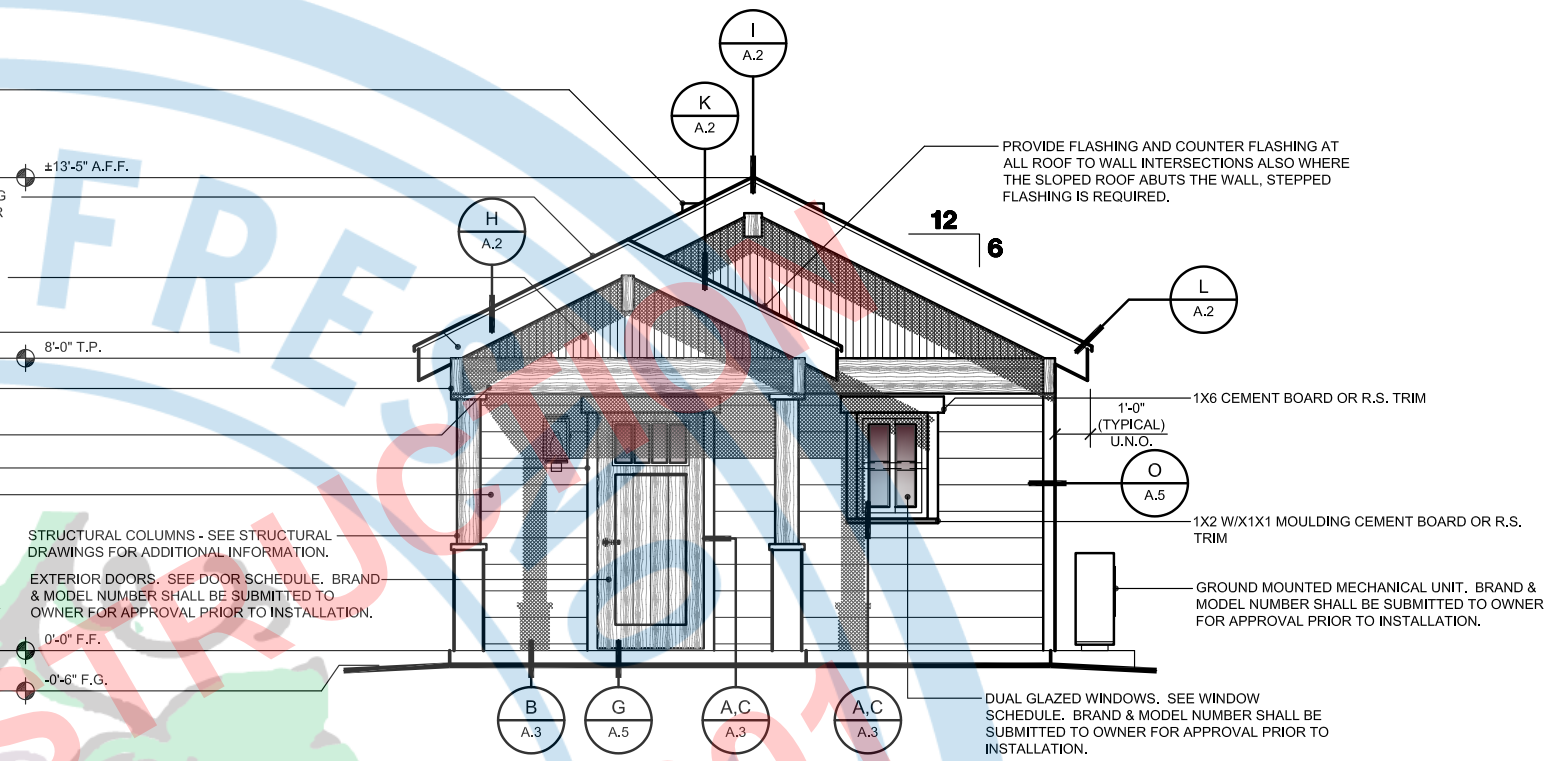

FRONT ELEVATION
CRAFTSMAN W/PORCH OPTION
MATERIALS AND SPECIFICATIONS ABOVE ARE APPLICABLE TO ALL SIDES OF THE ACCESSORY DWELLING UNIT.

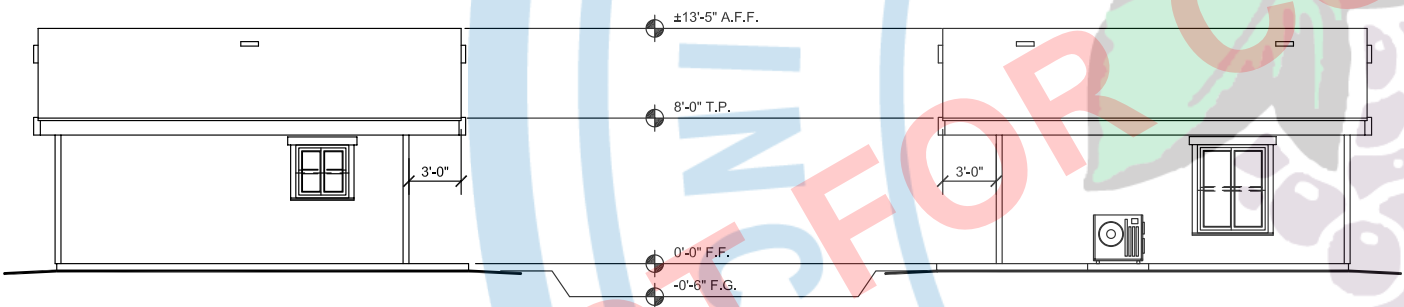

LEFT ELEVATION
CRAFTSMAN

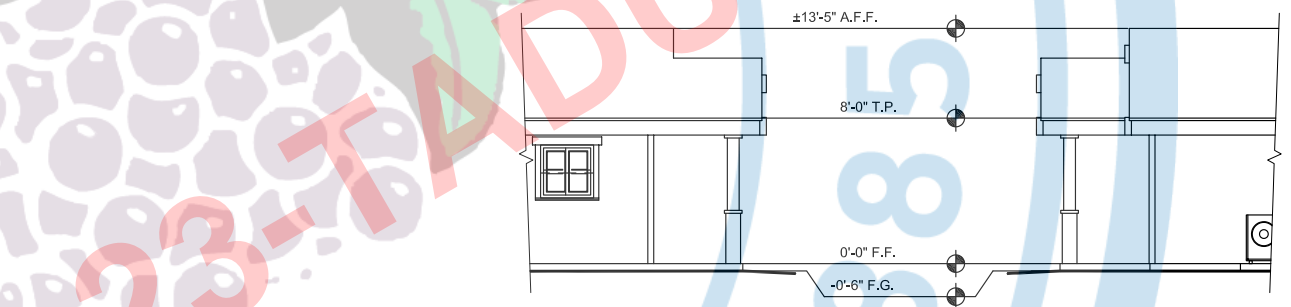

RIGHT ELEVATION
CRAFTSMAN

LEFT & RIGHT ELEVATION
CRAFTSMAN W/PORCH OPTION

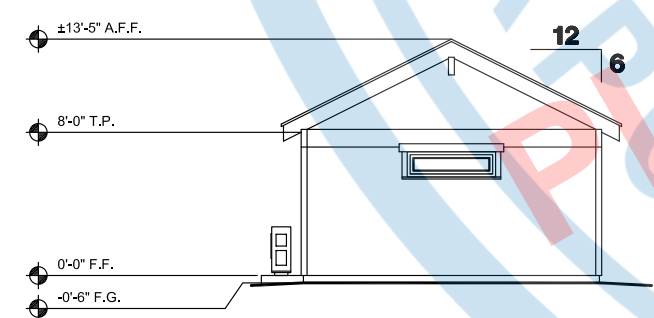

REAR ELEVATION
CRAFTSMAN

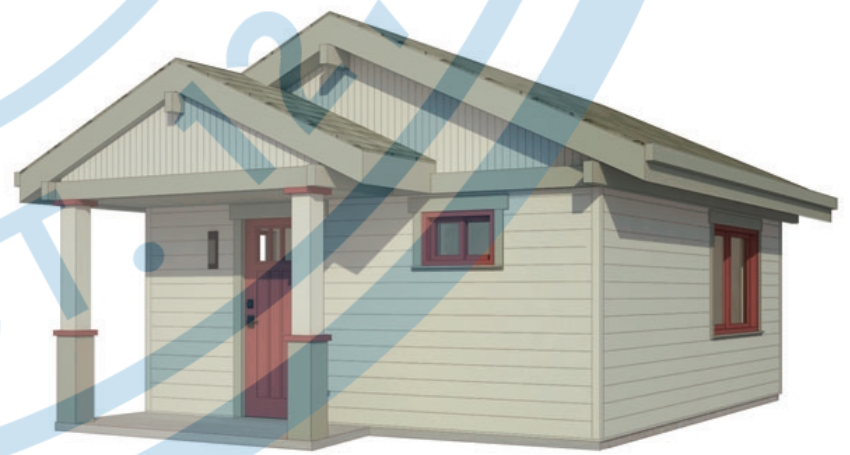

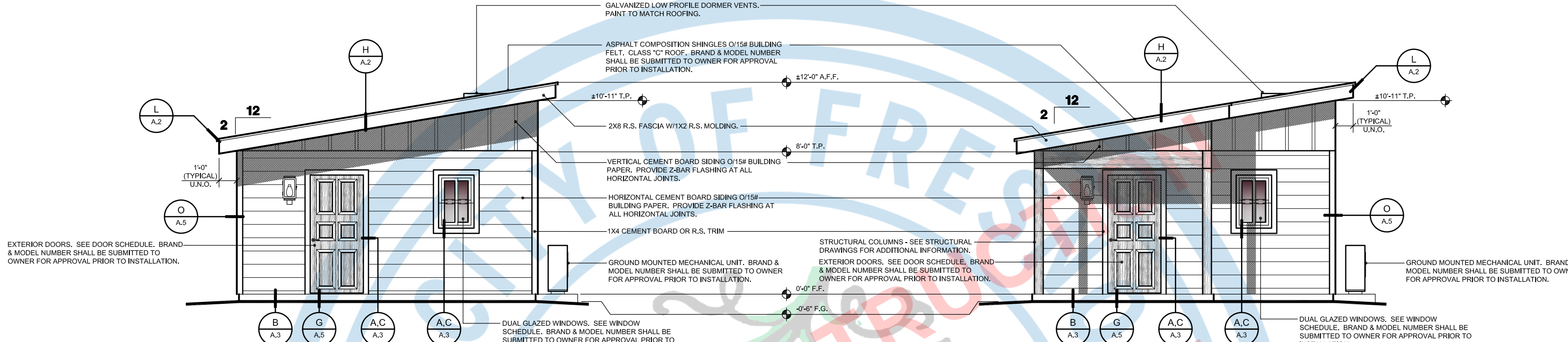

FRONT ELEVATION

CONTEMPORARY

MATERIALS AND SPECIFICATIONS ABOVE ARE APPLICABLE TO ALL SIDES OF THE ACCESSORY DWELLING UNIT.

FRONT ELEVATION

CONTEMPORARY W/PORCH OPTION

MATERIALS AND SPECIFICATIONS ABOVE ARE APPLICABLE TO ALL SIDES OF THE ACCESSORY DWELLING UNIT.

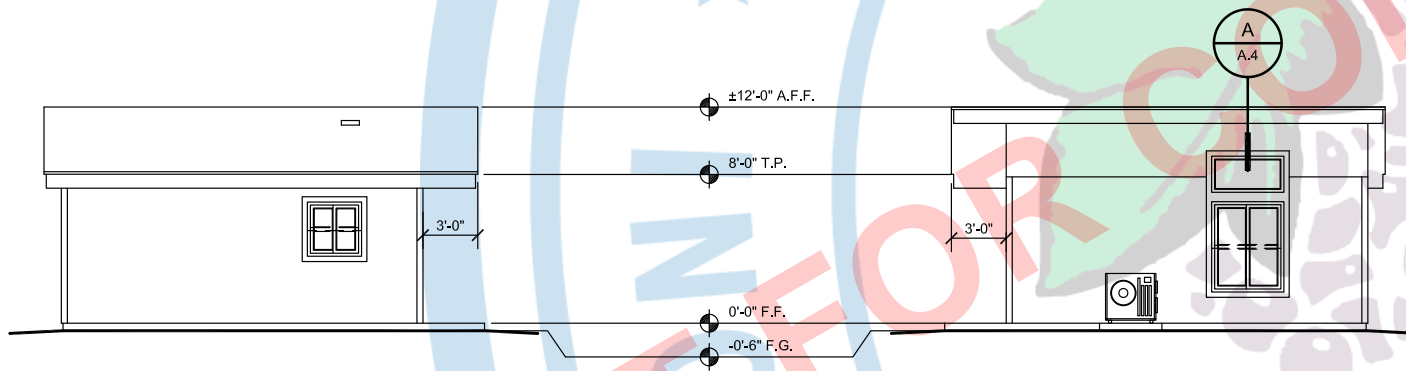

LEFT ELEVATION

CONTEMPORARY

RIGHT ELEVATION

CONTEMPORARY

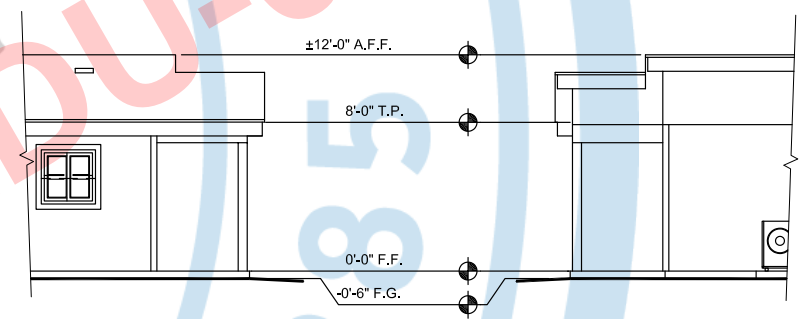

LEFT & RIGHT ELEVATION

CONTEMPORARY W/PORCH OPTION

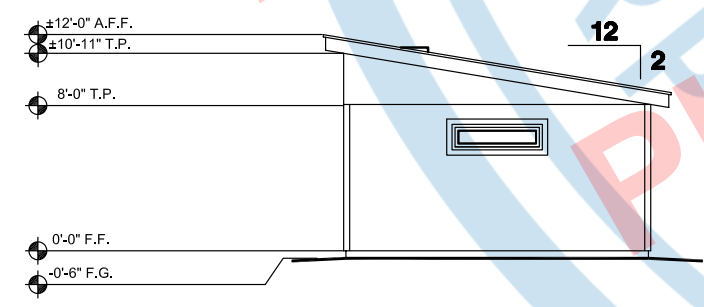

REAR ELEVATION

CONTEMPORARY

