

☒ DENOTES UNOBSTRUCTED PEDESTRIAN LANDING AREA PER ADA REQUIREMENTS PEDESTRIAN EASEMENT REQUIRED

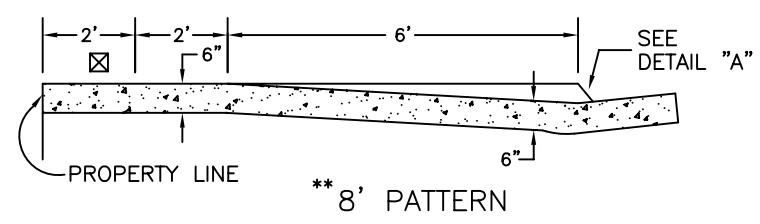

NOTE: CONSTRUCT WEAKENED PLANE JOINT ON CENTERLINE WHEN WIDTH IS 10 FEET OR GREATER.

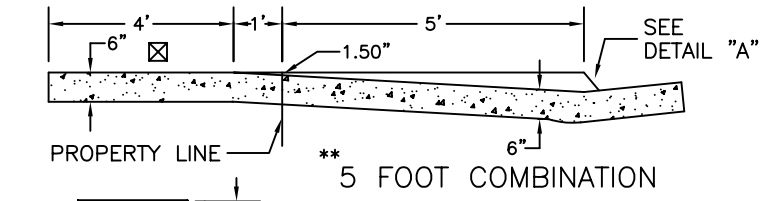
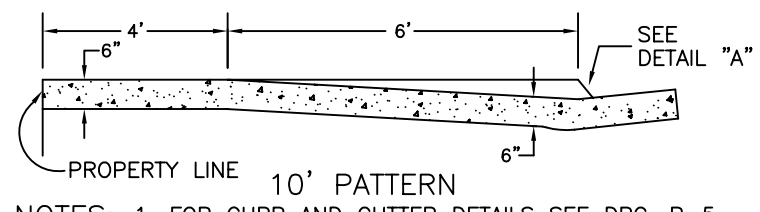

NOTES: 1. FOR CURB AND GUTTER DETAILS SEE DRG. P-5.
2. CONCRETE SHALL BE 6 SACK MIX.
** 5' AND 8' PATTERNS ARE FOR USE ON RETROFITS AND/OR WITH APPROVAL OF THE ENGINEER.

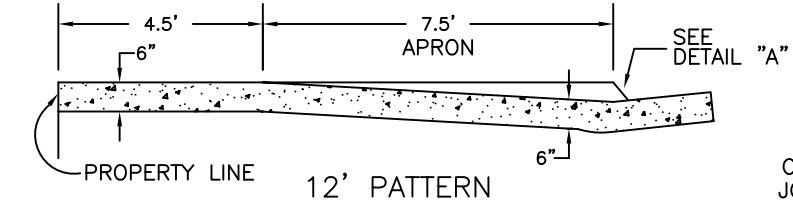

OPTION: APRON MAY BE EXTENDED TO THE NEAREST SCORE LINE GREATER THAN THE MINIMUM DISTANCE FROM THE CURB. MAXIMUM APRON SLOPE IS 0.9" PER FOOT
* MINIMUM LENGTH OF APRON

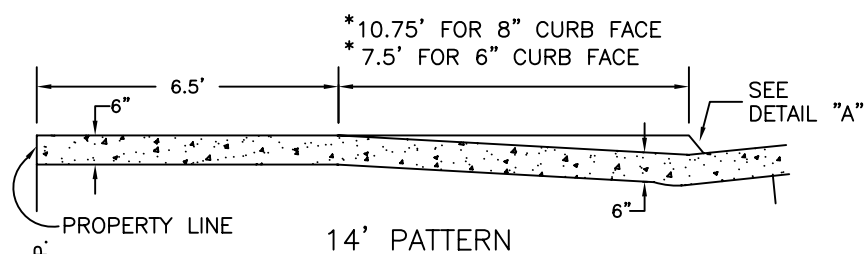

*10.75' FOR 8" CURB FACE
*7.5' FOR 6" CURB FACE

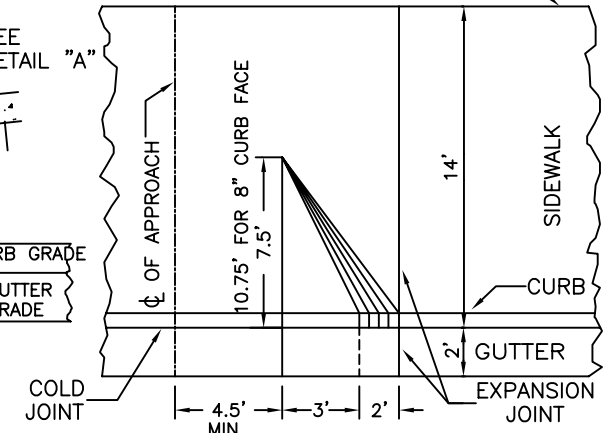
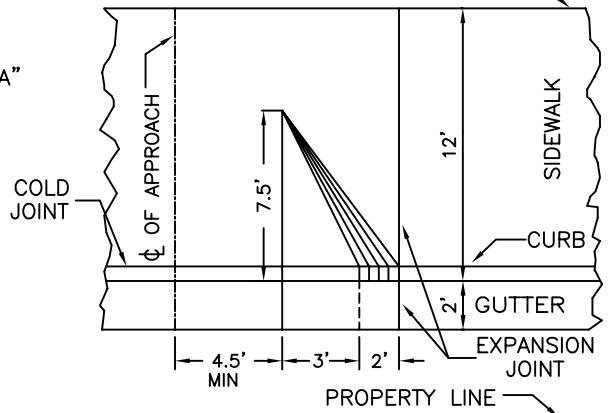
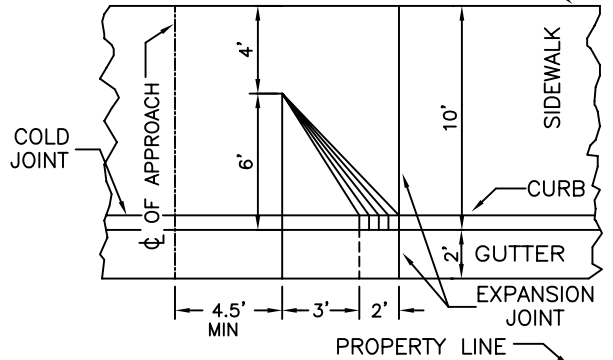
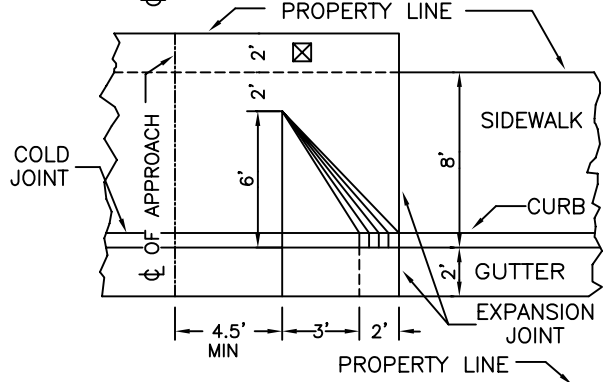
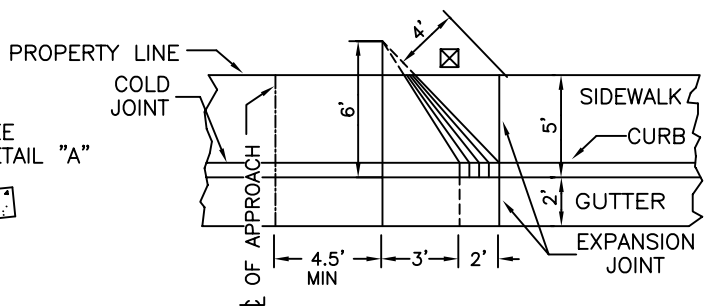
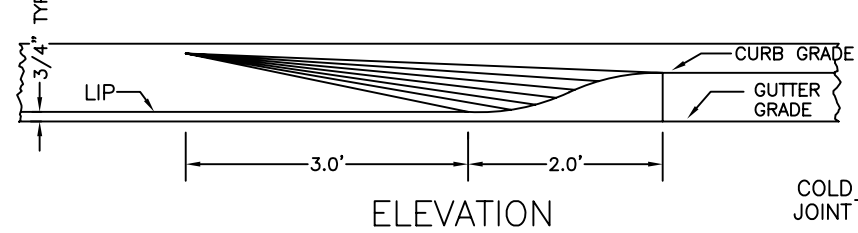

COMMERCIAL DRIVEWAY APPROACHES
FOR 14' - 12' - 10' - 8' PATTERN AND FOR
5' COMBINATION

REF. & REV.
DEC., 2004

CITY OF FRESNO
P-2