

□ DENOTES UNOBSTRUCTED ONSITE PEDESTRIAN LANDING AREA PER A.D.A. REQUIREMENTS
 □ PEDESTRIAN EASEMENT REQUIRED

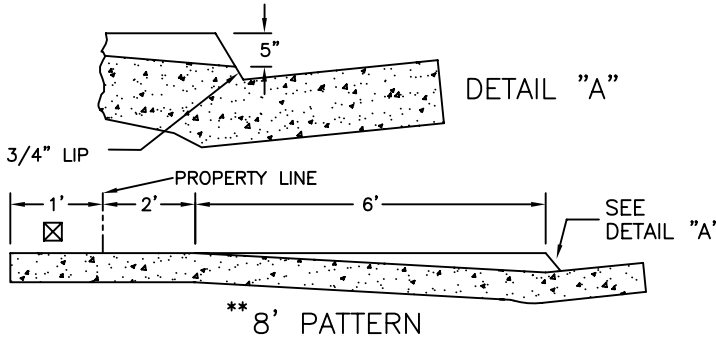

NOTE: CONSTRUCT WEAKENED PLANE JOINT ON CENTERLINE WHEN WIDTH IS 10 FEET OR GREATER.

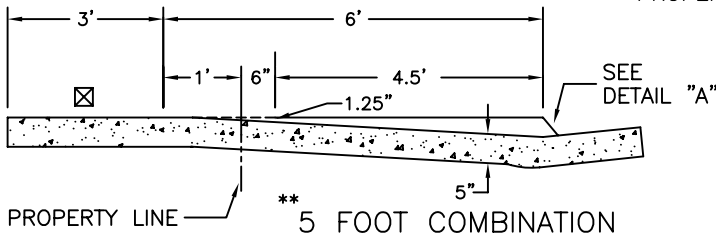
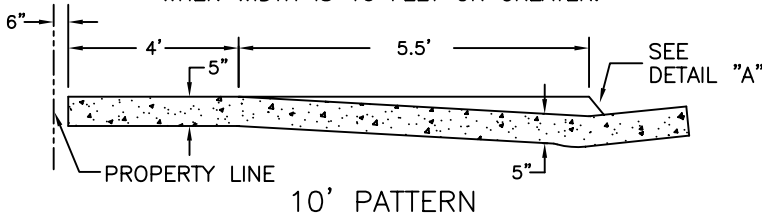

NOTES:

1. FOR CURB AND GUTTER DETAILS SEE DRG. P-5
- ** 2. 5' AND 8' PATTERNS ARE FOR USE ON RETROFITS AND/OR WITH APPROVAL OF THE ENGINEER.

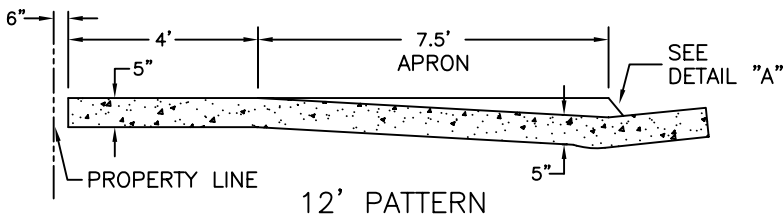

* MINIMUM LENGTH OF APRON

- * 10.75' FOR 8" CURB FACE
- * 7.5' FOR 6" CURB FACE

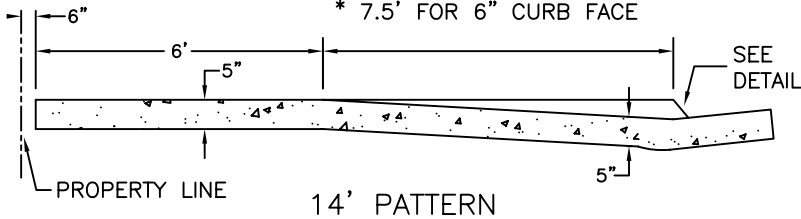

NOTE: DRIVEWAY APPROACH THICKNESS SHALL BE 6" WHEN USAGE IS OTHER THAN WITH NORMAL PASSENGER VEHICLES.

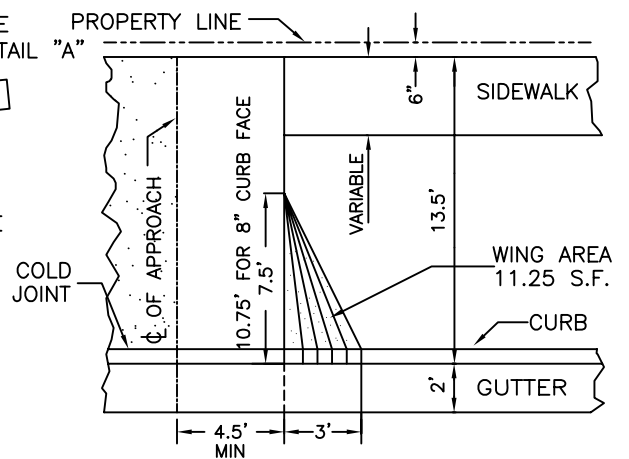
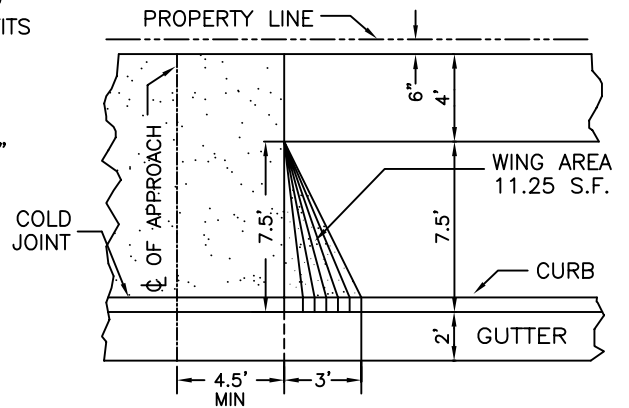
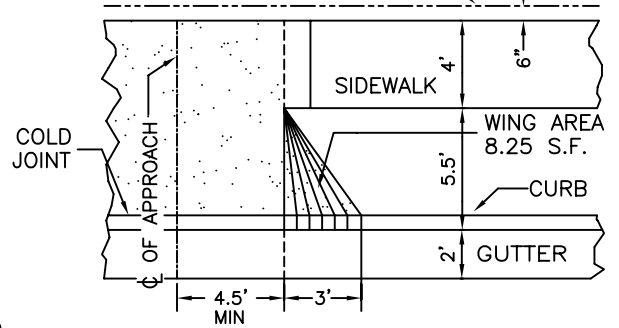
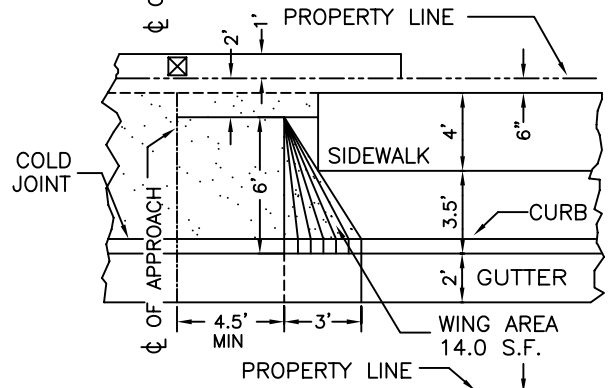
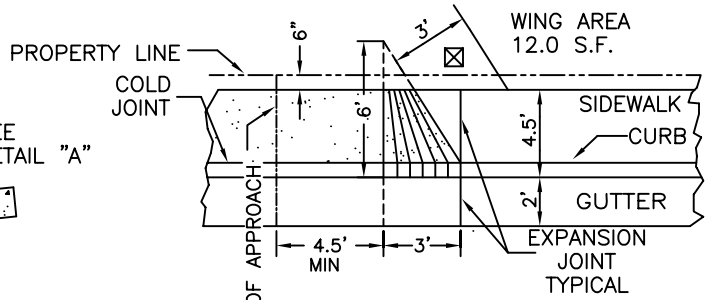
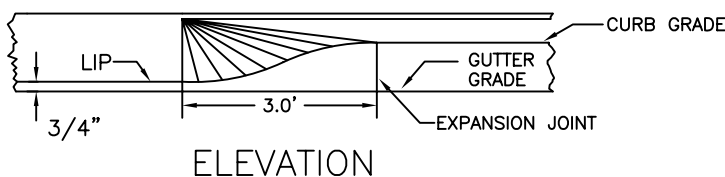

RESIDENTIAL DRIVEWAY APPROACHES
 FOR 14' - 12' - 10' - 8' PATTERN AND FOR
 5' COMBINATION

REF. & REV.
DEC., 2004

CITY OF FRESNO
 P-1