

PLAN VIEW

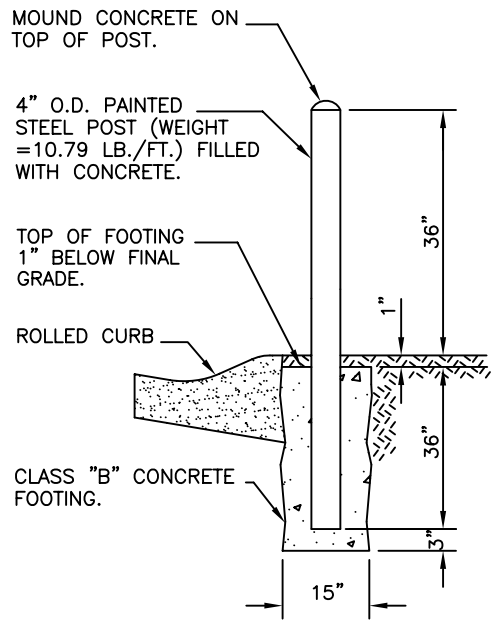

DETAIL OF STEEL GUARD POST

NOTES:

1. THE MAINTENANCE OF THE FIRE HYDRANT PROTECTOR POST SHALL BE THE RESPONSIBILITY OF THE HOMEOWNERS' ASSOCIATION, WITHIN PRIVATE STREETS.
2. IN THE EVENT ANY DAMAGE IS NOTED, THE CITY WILL NOTIFY THE HOMEOWNERS' ASSOCIATION TO PERFORM THE NECESSARY REPAIRS.
3. IF THE DAMAGE IS NOT REPAIRED WITHIN 30 CALENDAR DAYS FROM THE DATE OF THE CITY NOTICE, THE CITY SHALL PERFORM THE NECESSARY REPAIRS AND BILL THE HOMEOWNERS' ASSOCIATION FOR THE ASSOCIATED REPAIR COST.
4. POSTS SHALL BE KEPT IN GOOD REPAIR, AND SHALL BE CLEANED OR REPAINTED AS NECESSARY TO PRESERVE THEIR APPEARANCE.