

ALTERNATE SECTIONS

- 2"A.C./4"A.B. W/CONCRETE GUTTER-RESIDENTIAL
- 3"A.C. W/O CONCRETE GUTTER-RESIDENTIAL (LONG. S ≥ 0.0020)
- 4"A.C. W/CONCRETE GUTTER-COMMERCIAL
- 6"A.C. W/O CONCRETE GUTTER-COMMERCIAL (LONG. S ≥ 0.0020)
- 6"P.C.C. COMMERCIAL

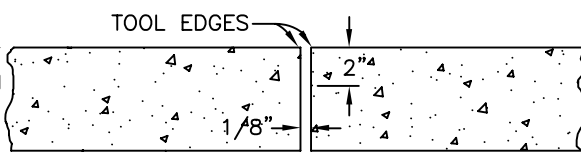
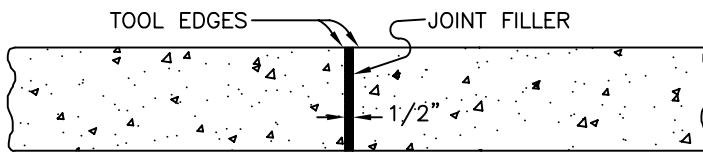
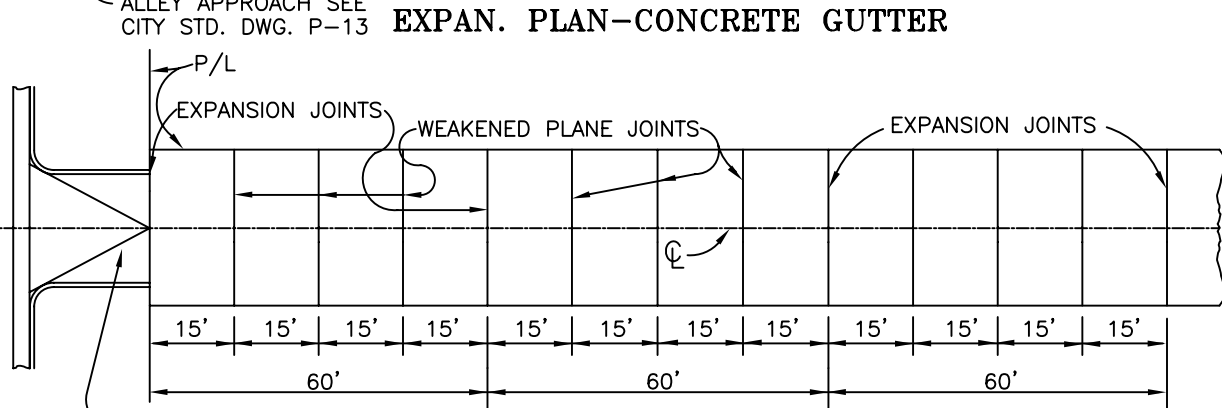
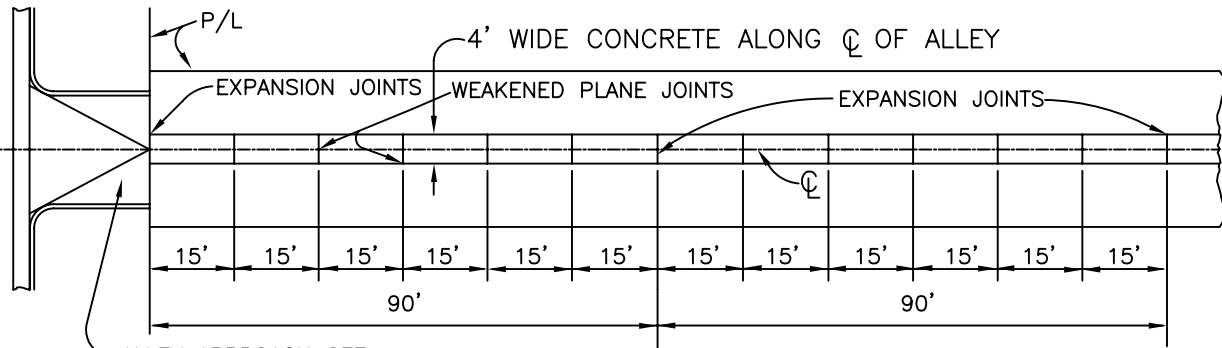
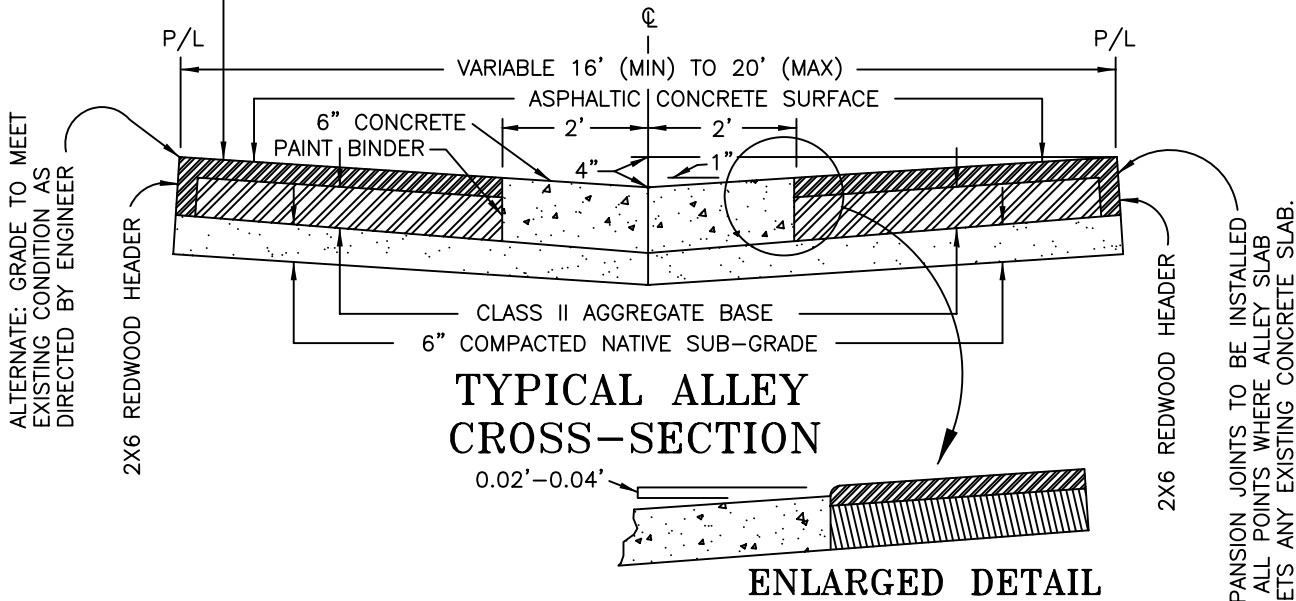

(REF. STATE STD. SPEC'S SEC. 51-1.12C) (SEE CITY STD. DWG. P-9 FOR ALTERNATE DESIGN)