

PLAN

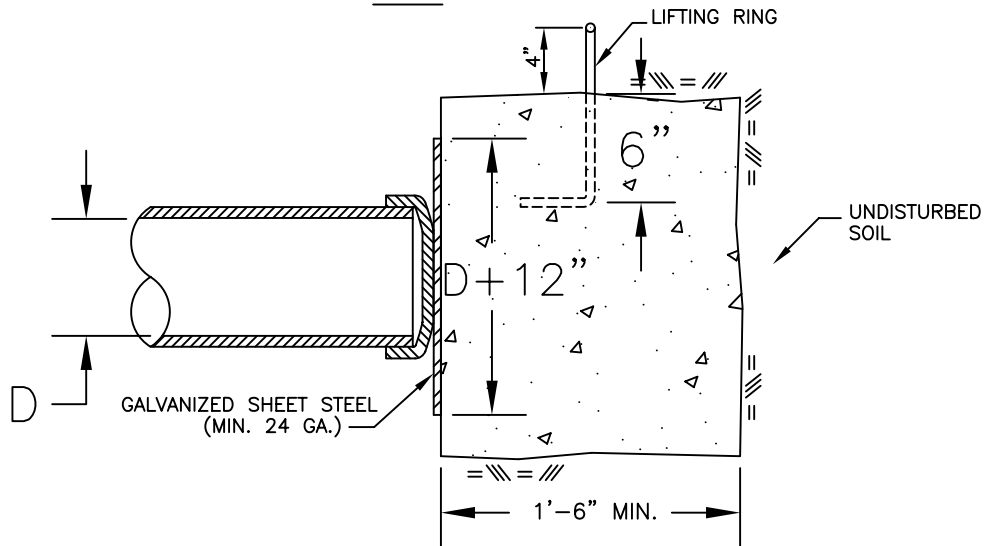

SECTION A-A

MINIMUM REQUIRED AREA FOR END OF BLOCK

NOMINAL PIPE DIAMETER (INCHES)	4	6	8	10	12	14	16	18	20	24
CONCRETE THRUST BLOCK MIN. AREA (SQ. FT.)	2	4	7	11	15	20	25	31	36	49

BASED ON 200 PSI LINE PRESSURE AND ALLOWABLE SOIL BEARING PRESSURE OF 1500 PSF.

NOTES:

- THRUST BLOCK SHALL BE USED FOR PIPES WITH 4" DIAMETER OR LARGER.
- PORTLAND CEMENT CONCRETE USED FOR THRUST BLOCKS SHALL BE MIN. 5 SACK CLASS B CONCRETE WITH A MAX. SLUMP OF 4 INCHES.
- CONCRETE SHALL BE POURED AGAINST UNDISTURBED EARTH EXCAVATION.
- BLOCKS SHALL HAVE LIFTING RING. USE NO. 5 BAR REINF. ROD TO FABRICATE RING AT CENTER OF BLOCK. FOR PIPES 16" DIAMETER OR LARGER, NO. 8 BAR REINF. ROD IS REQUIRED.
- CONCRETE, STEEL SHEET AND END OF PIPE SHALL BE ALL IN FULL CONTACT. NO CONCRETE SHALL BE PLACED IN CONTACT WITH WATER PIPE.
- TO KEEP THE EXCAVATION WALL SOLID AND UNDISTURBED, OVEREXCAVATION TO ACCOMMODATE THRUST BLOCK SHALL BE HAND EXCAVATED.
- AREA OF THRUST BLOCK MAY BE INCREASED IF WARRANTED BY SITE CONDITIONS.