

FOR ALL FIRE HYDRANTS INSTALLED, THE SETBACK SHALL TYPICALLY BE 30", BUT SHALL BE MODIFIED AS REQUIRED TO PROVIDE 4' MIN. SIDEWALK CLEARANCE FOR ADA COMPLIANCE.

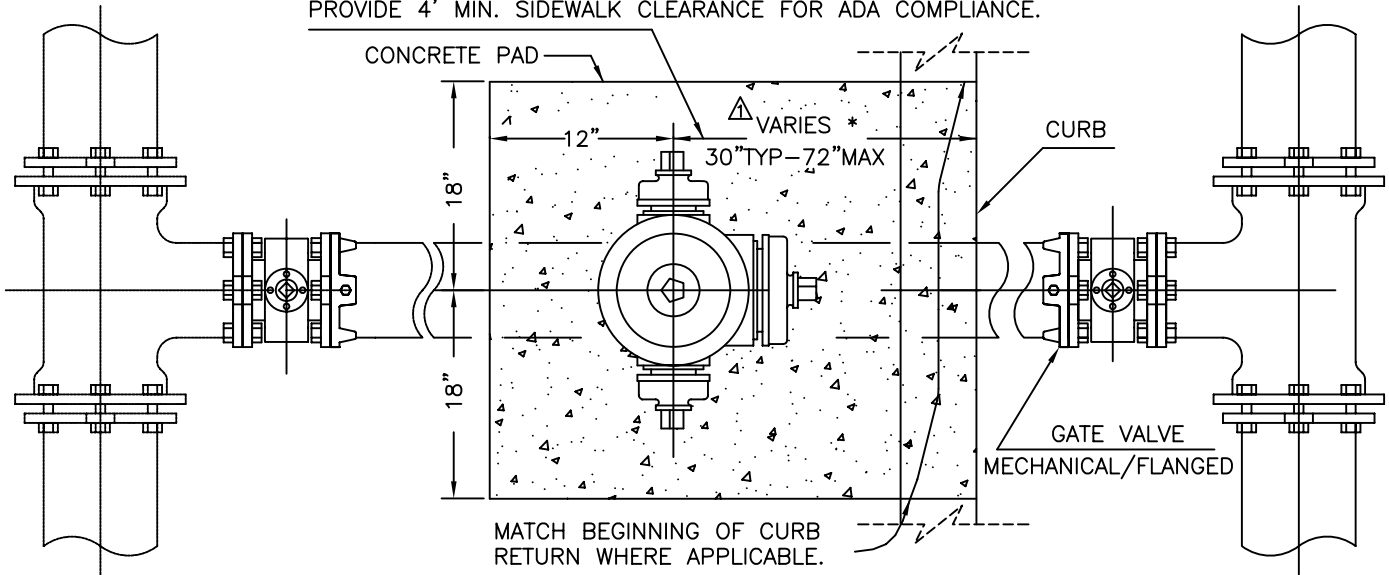

WHERE MAIN LIES BEHIND CURB, PIPE & VALVE DETAILS SHALL BE REVERSED.

△ \* PROVIDE 4' MIN. SIDEWALK CLEARANCE ADJACENT TO FIRE HYDRANT FOR ADA ACCESSIBILITY REQUIREMENTS.

NOTE: GATE VALVE TO BE TIED TO MAIN PER STD DWG W-37  
NOTE: CAP AND OPERATING NUTS ARE 1 1/8" PENTAGON.

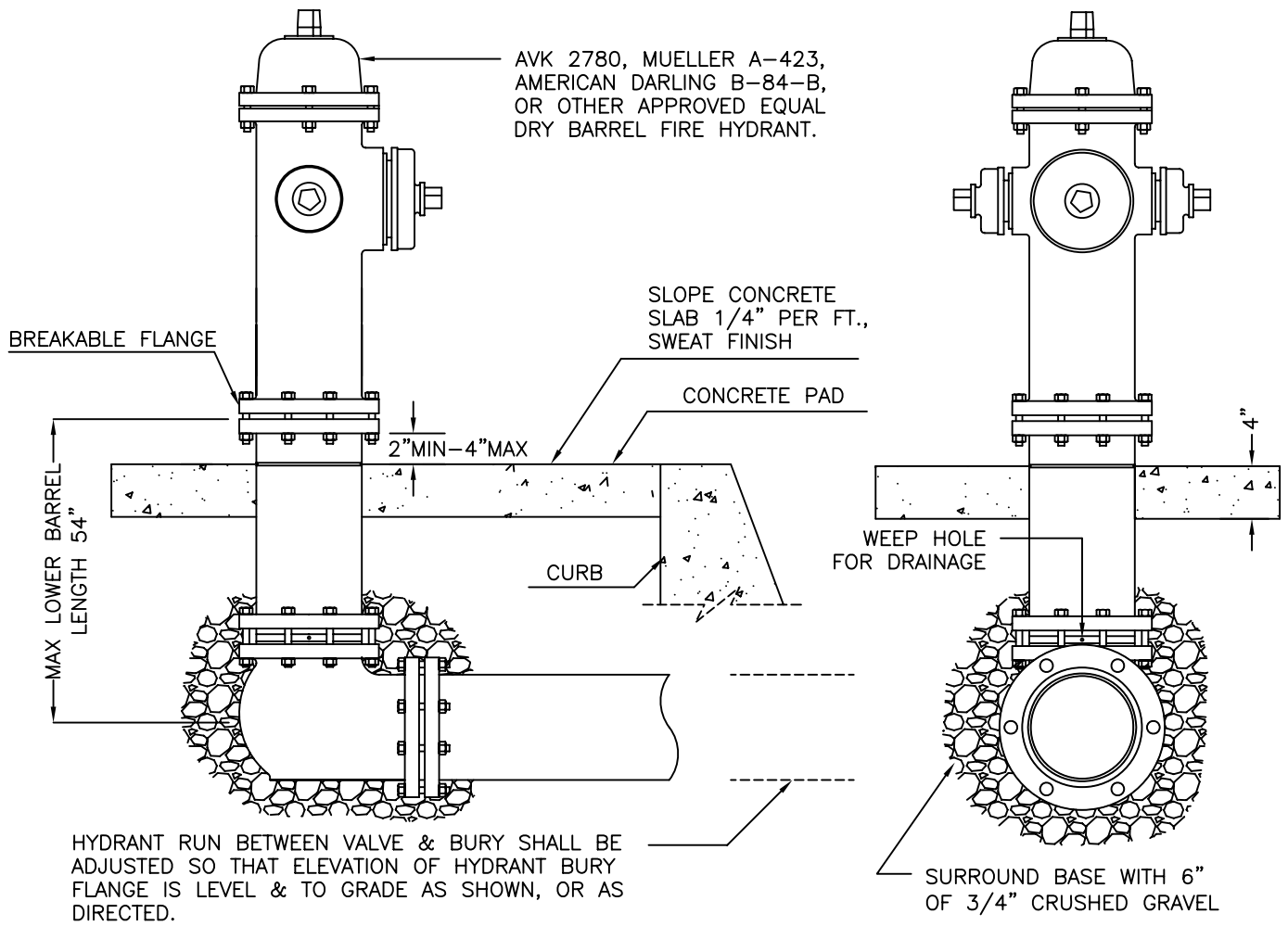

HYDRANT RUN BETWEEN VALVE & BURY SHALL BE ADJUSTED SO THAT ELEVATION OF HYDRANT BURY FLANGE IS LEVEL & TO GRADE AS SHOWN, OR AS DIRECTED.

# FIRE HYDRANT INSTALLATION

REF. & REV.  
DEC., 2003  
△ JAN., 1997

CITY OF FRESNO  
W-3